

## **Chapter 8**

### **DC Inductor Design Using Gapped Cores**

## Table of Contents

1. Introduction .....	
2. Critical Inductance for Sine Wave Rectification .....	
3. Critical Inductance for Buck Type Converters .....	
4. Core Materials, Used in PWM Converters .....	
5. Fundamental Considerations .....	
6. Fringing Flux .....	
7. Inductors .....	
8. Relationship of, $A_p$ , to Inductor's Energy-Handling Capability .....	
9. Relationship of, $K_g$ , to Inductor's Energy-Handling Capability .....	
10. Gapped Inductor Design Example Using the Core Geometry, $K_g$ , Approach.....	
11. Gapped Inductor Design Example Using the Area Product, $A_p$ , Approach .....	

## Introduction

Designers have used various approaches in arriving at suitable inductor designs. For example, in many cases, a rule of thumb used for dealing with current density is that a good working level is 200 amps-per-cm<sup>2</sup> (1000 Cir-Mils-per-amp). This rule is satisfactory in many instances; however, the wire size used to meet this requirement may produce a heavier and bulkier inductor than desired or required. The information presented herein will make it possible to avoid the use of this and other rules of thumb and to develop an economical and a better design.

## Critical Inductance for Sine Wave Rectification

The LC filter is the basic method of reducing ripple levels. The two basic rectifier circuits are the full-wave center-tap as shown in Figure 8-1 and the full-wave bridge, as shown in Figure 8-2. To achieve normal inductor operation, it is necessary that there be a continuous flow of current through the input inductor, L1.

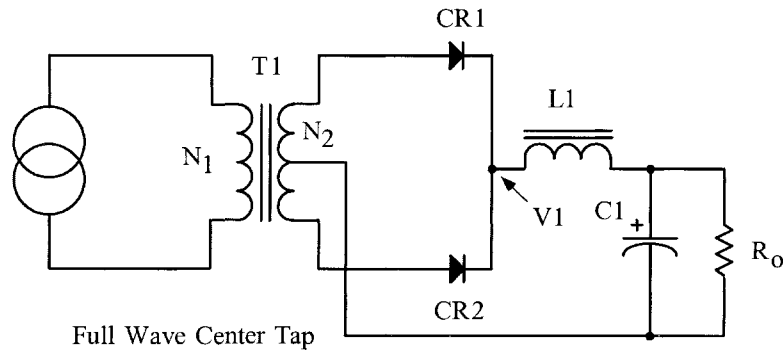

Figure 8-1. Full-Wave Center Tap with an LC filter.

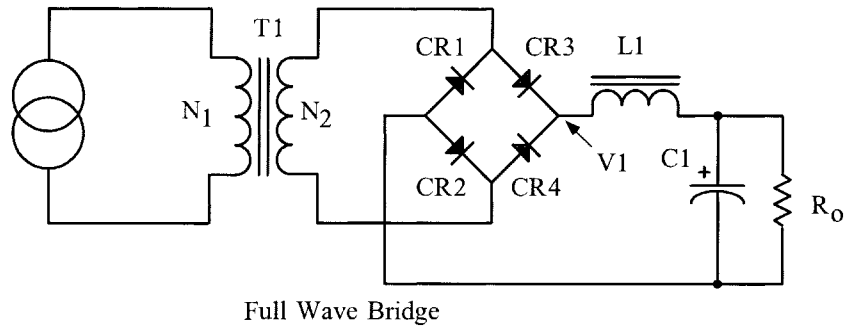

Figure 8-2. Full-Wave Bridge with an LC filter.

The value for minimum inductance called critical inductance,  $L_{(crit)}$  is:

$$L_{(crit)} = \frac{R_{o(max)}}{3\omega}, \text{ [henrys] [8-1]}$$

Where:

$$\omega = 2\pi f$$

$$f = \text{line frequency}$$

The higher the load resistance,  $R_o$ , (i.e., the lower the dc load current), the more difficult it is to maintain a continuous flow of current. The filter inductor operates in the following manner: When  $R_o$  approaches infinity, under an unloaded condition, (no bleeder resistor),  $I_o = 0$ , the filter capacitor will charge to  $V_{1pk}$ , the peak voltage. Therefore, the output voltage will be equal to the peak value of the input voltage, as shown in Figure 8-3.

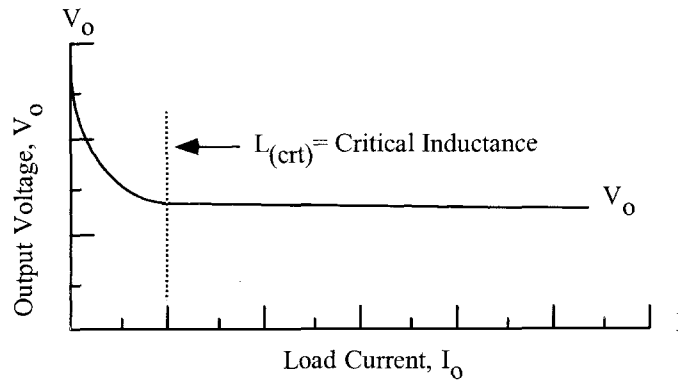

**Figure 8-3.** Critical Inductance Point.

The ripple reduction from a single stage LC filter can be calculated, using Equation 8-2 and Figure 8-4.

$$V_{r(pk)} = V_{in(pk)} \left( \frac{1}{(2\pi f)^2 L1C1} \right), \text{ [volts-peak] [8-2]}$$

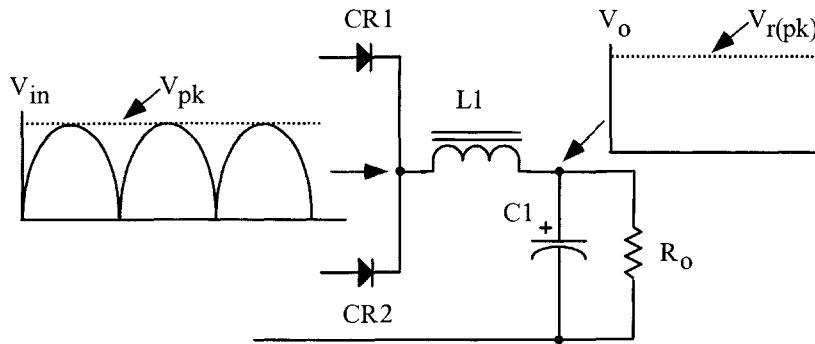
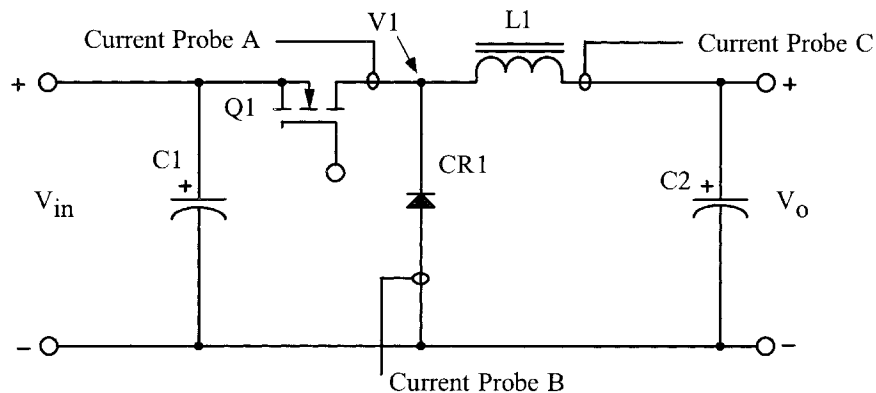

**Figure 8-4.** LC Filter Ripple Reduction.

## Critical Inductance for Buck Type Converters

The buck type converter schematic is shown in Figure 8-5, and the buck type dc-to-dc converter is shown in Figure 8.6. The buck regulator filter circuit shown in Figure 8-5 has three current probes. These current probes monitor the three basic currents in a switch mode, buck output filter. Current probe A monitors the power MOSFET, Q1, switching current. Current probe B monitors the commutating current through CR1. Current probe C monitors the current through the output inductor, L1.

The typical filter waveforms of the buck converter are shown in Figure 8-7. The waveforms are shown with the converter operating at a 0.5 duty ratio. The applied voltage, V1 to the filter, is shown in Figure 8-7A. The power MOSFET, Q1, current is shown in Figure 8-7B. The commutating current flowing through CR1 is shown in Figure 8-7C. The commutating current is the result of Q1 being turned off, and the field in L1 collapsing, producing the commutating current. The current flowing through L1 is shown in Figure 8-7D. The current flowing through L1 is the sum of the currents in Figure 8-7B and 8-7C.



**Figure 8-5.** Buck Regulator Converter.

The critical inductance current is shown in Figure 8-8, 8-B and is realized in Equation 8-3. The critical inductance current is when the ratio of the delta current to the output load current is equal to  $2 = \Delta I / I_o$ . If the output load current is allowed to go beyond this point, the current will become discontinuous, as shown in Figure 8-8, 8-D. The applied voltage, V1, will have ringing at the level of the output voltage, as shown in Figure 8-8, 8-C. When the current in the output inductor becomes discontinuous, as shown in Figure 8-8, 8-D, the response time for a step load becomes very poor.

When designing multiple output converters similar to Figure 8-6, the slaved outputs should never have the current in the inductor go discontinuous or to zero. If the current goes to zero, a slaved output voltage will rise to the value of V1. If the current is allowed to go to zero, then, there is no potential difference between the input and output voltage of the filter. Then the output voltage will rise to equal the peak input voltage.

$$L_{(critical)} = \frac{V_o T (1 - D_{(min)})}{2I_{o(min)}}, \text{ [henrys] [8-3]}$$

$$D_{(min)} = \frac{V_o}{(\eta V_{in(max)})} \text{ [8-4]}$$

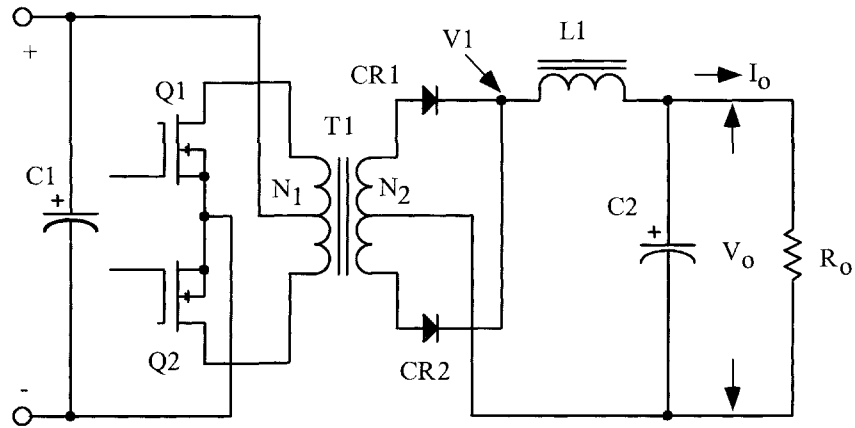

Figure 8-6. Push-Pull Buck Type Converter.

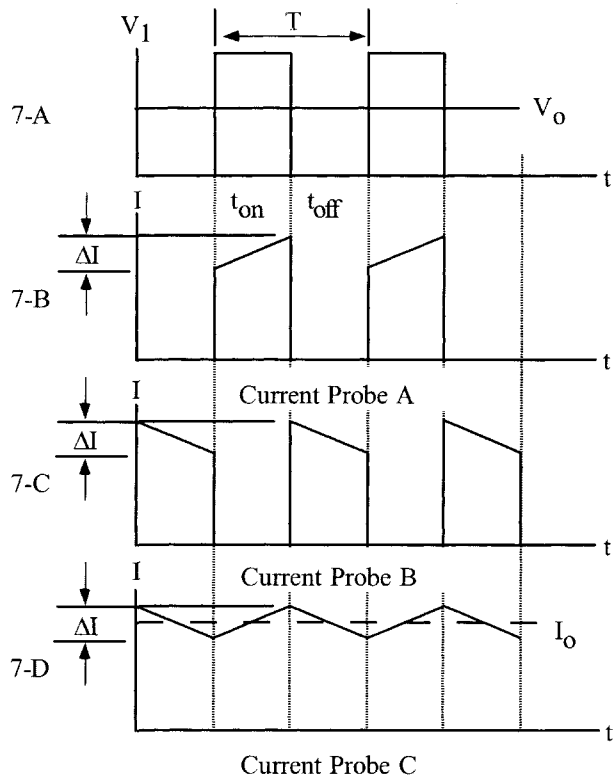
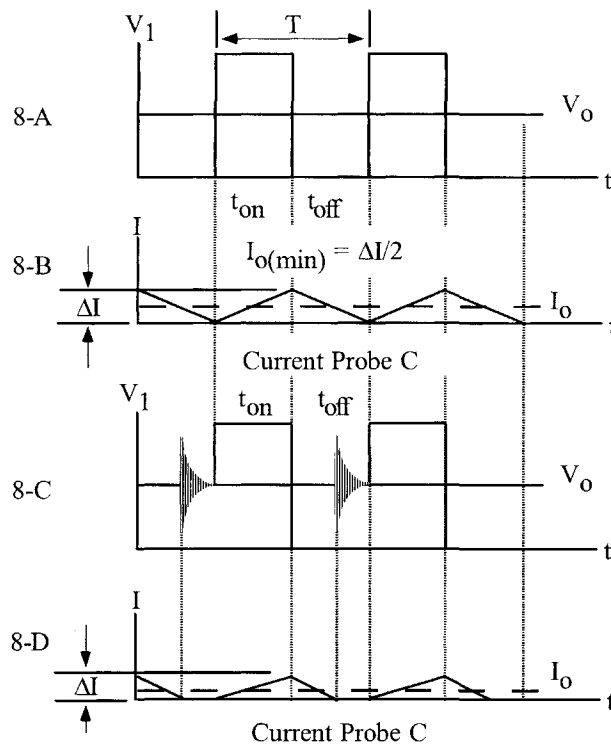

Figure 8-7. Typical Buck Converter Waveforms, Operating at a 0.5 Duty Ratio.



**Figure 8-8.** Buck Converter, Output Filter Inductor Goes from Critical to Discontinuous Operation.

### Core Materials, Used in PWM Converters

Designers have routinely tended to specify Molypermalloy powder materials for filter inductors used in high-frequency, power converters and pulse-width-modulators (PWM) switched regulators, because of the availability of manufacturers' literature containing tables, graphs, and examples that simplify the design task. Use of these cores may result in an inductor design not optimized for size and weight. For example, as shown in Figure 8-9, Molypermalloy powder cores, operating with a dc bias of  $0.3T$ , have only about 80% of the original inductance, with very rapid falloff at higher flux densities. When size is of greatest concern then, magnetic materials with high flux saturation,  $B_s$ , would be first choice. Materials, such as silicon or some amorphous materials, have approximately four times the useful flux density compared to Molypermalloy powder cores. Iron alloys retain 90% of their original inductance at greater than  $1.2T$ . Iron alloys, when designed correctly and used in the right application, will perform well at frequencies up to 100kHz. When operating above 100kHz, then the only material is ferrite. Ferrite materials have a negative temperature coefficient regarding flux density. The operating temperature and temperature rise should be used to calculate the maximum flux density.

To get optimum performance, together with size, the engineer must evaluate the materials for both,  $B_s$ , and  $B_{ac}$ . See Table 8-1. The operating dc flux has only to do with  $I^2R$  losses, (copper). The ac flux,  $B_{ac}$ , has to do with core loss. This loss depends directly on the material. There are many factors that impact a design: cost, size, temperature rise and material availability.

There are significant advantages to be gained by the use of iron alloys and ferrites in the design of power inductors, despite certain disadvantages, such as the need for banding and gapping materials, banding tools, mounting brackets, and winding mandrels.

Iron alloys and ferrites provide greater flexibility in the design of high frequency power inductors, because the air gap can be adjusted to any desired length, and because the relative permeability is high, even at high, dc flux density.

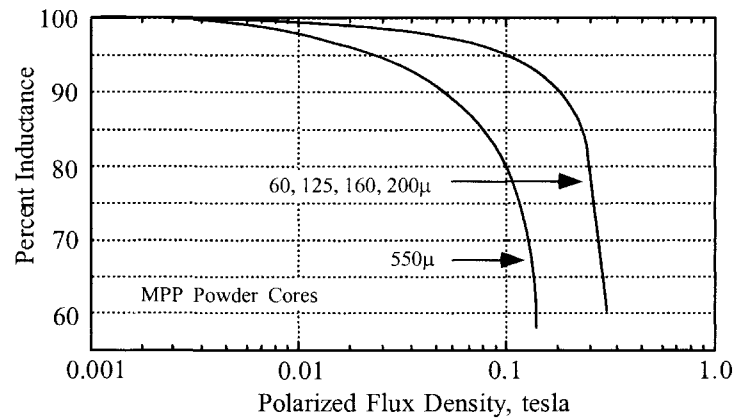

**Figure 8-9.** Inductance Versus dc Bias.

**Table 8-1.** Magnetic Material Properties

<b>Magnetic Material Properties</b>					
Material Name	Composition	Initial Permeability $\mu_i$	Flux Density Tesla $B_s$	Curie Temp. °C	Density grams/cm <sup>3</sup> $\delta$
Silicon	3-97 SiFe	1500	1.5-1.8	750	7.63
Orthonol	50-50 NiFe	2000	1.42-1.58	500	8.24
Permalloy	80-20 NiFe	25000	0.66-0.82	460	8.73
Amorphous	81-3.5 FeSi	1500	1.5-1.6	370	7.32
Amorphous	66-4 CoFe	800	0.57	250	7.59
Amorphous( $\mu$ )	73-15 FeSi	30000	1.0-1.2	460	7.73
Ferrite	MnZn	2500	0.5	>230	4.8



## Fundamental Considerations

The design of a linear reactor depends upon four related factors:

1. Desired inductance,  $L$
2. Direct current,  $I_{dc}$
3. Alternating current,  $\Delta I$
4. Power loss and temperature,  $T_r$

With these requirements established, the designer must determine the maximum values for,  $B_{dc}$ , and,  $B_{ac}$ , that will not produce magnetic saturation. The designer must make trade-offs that will yield the highest inductance for a given volume. It should be remembered the peak operating flux,  $B_{pk}$ , depends upon,  $B_{dc}$  +  $B_{ac}$ , in the manner in Figure 8-10.

$$B_{pk} = B_{dc} + \frac{B_{ac}}{2}, \quad [\text{tesla}] \quad [8-5]$$

$$B_{dc} = \frac{0.4\pi N I_{dc} (10^{-4})}{l_g + \left(\frac{MPL}{\mu_m}\right)}, \quad [\text{tesla}] \quad [8-6]$$

$$B_{ac} = \frac{0.4\pi N \left(\frac{\Delta I}{2}\right) (10^{-4})}{l_g + \left(\frac{MPL}{\mu_m}\right)}, \quad [\text{tesla}] \quad [8-7]$$

$$B_{pk} = \frac{0.4\pi N \left(I_{dc} + \frac{\Delta I}{2}\right) (10^{-4})}{l_g + \left(\frac{MPL}{\mu_m}\right)}, \quad [\text{tesla}] \quad [8-8]$$

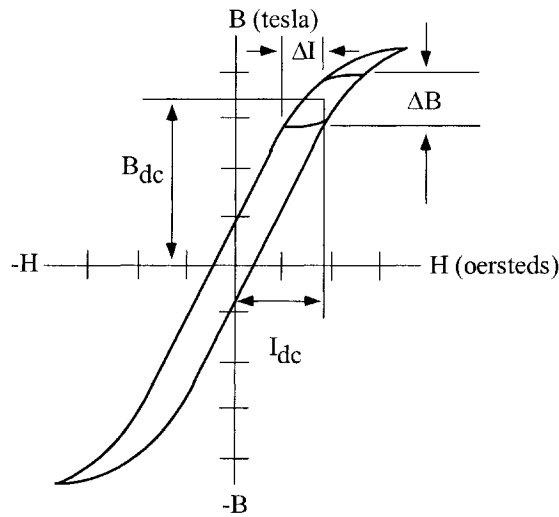

**Figure 8-10.** Inductor Flux Density Versus  $I_{dc} + \Delta I$  Current.

The inductance of an iron-core inductor carrying direct current and having an air gap may be expressed as:

$$L = \frac{0.4\pi N^2 A_c (10^{-8})}{l_g + \left(\frac{MPL}{\mu_m}\right)}, \text{ [henrys] [8-9]}$$

This equation shows that inductance is dependent on the effective length of the magnetic path, which is the sum of the air gap length,  $l_g$ , and the ratio of the core mean length to the material permeability,  $MPL/\mu_m$ . When the core air gap,  $l_g$ , is large compared to the ratio,  $MPL/\mu_m$ , because of material permeability,  $\mu_m$ , variations in  $\mu_m$  do not substantially affect the total effective magnetic path length or the inductance. Then the inductance Equation [8-9] reduces to:

$$L = \frac{0.4\pi N^2 A_c (10^{-8})}{l_g}, \text{ [henrys] [8-10]}$$

Final determination of the air gap size requires consideration of the effect of fringing flux, which is a function of gap dimension, the shape of the pole faces, and the shape, size, and location of the winding. Its net effect is to shorten the air gap. Because of the fringing flux it is wise to lower the initial operating flux density, 10 to 20%.

### **Fringing Flux**

Fringing flux decreases the total reluctance of the magnetic path and therefore, increases the inductance by a factor,  $F$ , to a value greater than that calculated from Equation 8-10. Fringing flux is a larger percentage of the total for the larger gaps.

The fringing factor is:

$$F = 1 + \frac{l_g}{\sqrt{A_c}} \ln \left( \frac{2G}{l_g} \right) \quad [8-11]$$

Where G is the winding length, defined in Chapter 3. This equation is valid for laminations, C cores and cut ferrites. Equation [8-11] is plotted in Figure 8-11.

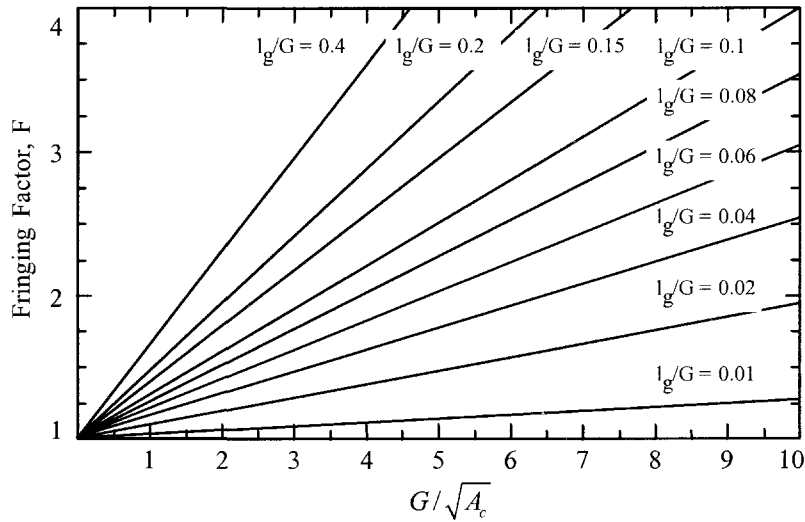
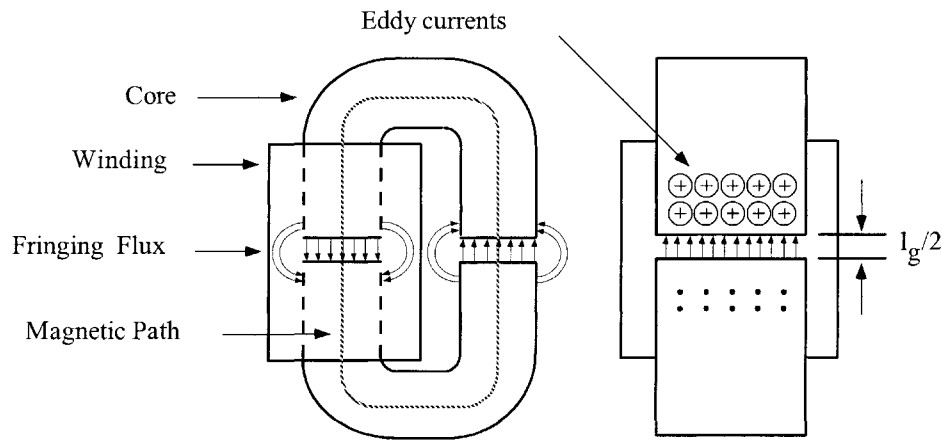

**Figure 8-11.** Increase of Inductance with Fringing Flux at the Gap.

As the air gap increases, the flux across the gap fringes more and more. Some of the fringing flux strikes the core, perpendicular to the strip or tape, and sets up eddy currents, which cause additional losses in the core. If the gap dimension gets too large, the fringing flux will strike the copper winding and produce eddy currents, generating heat, just like an induction heater. The fringing flux will jump the gap and produce eddy currents, in both the core and winding, as shown in Figure 8-12.

The inductance, L computed in Equation [8-10], does not include the effect of the fringing flux. The value of inductance, L' corrected for fringing flux is:

$$L' = \frac{0.4\pi N^2 F A_c (10^{-8})}{l_g}, \quad [\text{henrys}] \quad [8-12]$$



**Figure 8-12.** Fringing Flux Around the Gap of an Inductor.

The effective permeability may be calculated from the following equation:

$$\mu_e = \frac{\mu_m}{1 + \left(\frac{l_g}{MPL}\right)\mu_m} \quad [8-13]$$

Where,  $\mu_m$ , is the material permeability.

### Inductors

Inductors that carry direct current are used frequently in a wide variety of ground, air, and space applications. Selection of the best magnetic core for an inductor frequently involves a trial-and-error type of calculation.

The author has developed a simplified method of designing optimum, dc carrying inductors with gapped cores. This method allows the engineer to select the proper core that will provide correct copper loss, and make allowances for fringing flux, without relying on trial-and-error and the use of the cumbersome Hanna's curves.

Rather than discuss the various methods used by transformer designers, the author believes it is more useful to consider typical design problems, and to work out solutions using the approach based upon newly formulated relationships. Two gapped core designs will be compared. To compare their merits, the first design example will use the core geometry,  $K_g$ , and the second design will use the area product,  $A_p$ .

Inductors, designed in this handbook, are banded together with phosphor bronze banding material, or held together with aluminum brackets. The use of steel banding material; or brackets that bridge the gap are not recommended, because the use of steel across the gap is called shorting the gap. When the gap is shorted, the inductance will increase from the calculated value.

## Relationship of, $A_p$ , to Inductor's Energy-Handling Capability

The energy-handling capability of a core is related to its area product,  $A_p$ , by the equation:

$$A_p = \frac{2(\text{Energy})(10^4)}{B_m J K_u}, \quad [\text{cm}^4] \quad [8-14]$$

Where: Energy is in watt-seconds.

$B_m$  is the flux density, tesla.

$J$  is the current density, amps-per-cm<sup>2</sup>.

$K_u$  is the window utilization factor. (See Chapter 4)

From the above, it can be seen that factors such as flux density,  $B_m$ , window utilization factor,  $K_u$ , (which defines the maximum space that may be used by the copper in the window), and the current density,  $J$ , which controls the copper loss, all impact the area product,  $A_p$ . The energy-handling capability of a core is derived from:

$$\text{Energy} = \frac{LI^2}{2}, \quad [\text{watt-seconds}] \quad [8-15]$$

## Relationship of, $K_g$ , to Inductor's Energy-Handling Capability

Inductors, like transformers, are designed for a given temperature rise. They can also be designed for a given regulation. The regulation and energy handling ability of a core is related to two constants:

$$\alpha = \frac{(\text{Energy})^2}{K_g K_e}, \quad [\%] \quad [8-16]$$

Where,  $\alpha$ , is the regulation, %:

The constant,  $K_g$ , is determined by the core geometry:

$$K_g = \frac{W_a A_c^2 K_u}{MLT}, \quad [\text{cm}^5] \quad [8-17]$$

The constant,  $K_e$ , is determined by the magnetic and electrical operating conditions:

$$K_e = 0.145 P_o B_{pk}^2 (10^{-4}) \quad [8-18]$$

The peak operating flux density,  $B_{pk}$ , is:

$$B_{pk} = B_{dc} + \frac{B_{ac}}{2}, \quad [\text{tesla}] \quad [8-19]$$

From the above, it can be seen that the flux density,  $B_{pk}$ , is the predominant factor governing size.

The output power,  $P_o$ , is defined in Figure 8-13.

$$P_{o(L1)} = V_{(01)} I_{(01)} \quad P_{o(L2)} = V_{(02)} I_{(02)} \quad [8-20]$$

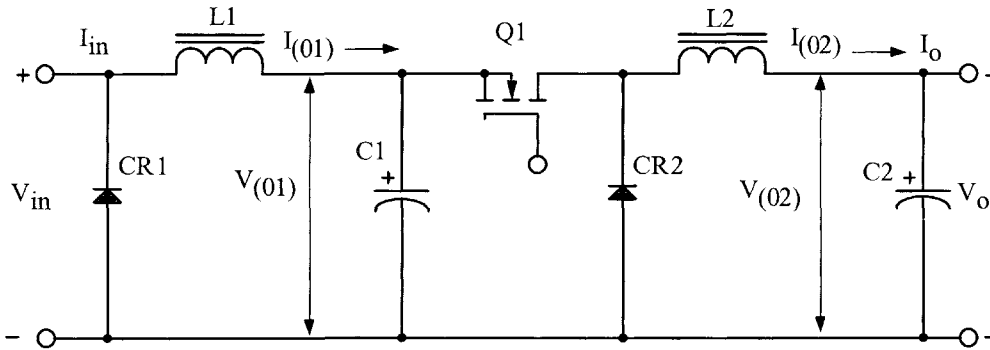

Figure 8-13. Defining the Inductor Output Power.

### Gapped Inductor Design Example Using the Core Geometry, $K_g$ , Approach

Step No. 1 Design a linear dc inductor with the following specifications.

1. Inductance, L ..... = 0.0025 henrys
2. dc current,  $I_o$  ..... = 1.5 amps
3. ac current,  $\Delta I$  ..... = 0.2 amps
4. Output power,  $P_o$  ..... = 100 watts
5. Regulation,  $\alpha$  ..... = 1.0 %
6. Ripple Frequency ..... = 200 kHz
7. Operating flux density,  $B_m$  ..... = 0.22 tesla
8. Core Material ..... = ferrite
9. Window utilization,  $K_u$  ..... = 0.4
10. Temperature rise goal,  $T_r$  ..... = 25°C

Step No. 2 Calculate the peak current,  $I_{pk}$ .

$$I_{pk} = I_o + \frac{\Delta I}{2}, \quad [\text{amps}]$$

$$I_{pk} = (1.5) + \frac{(0.2)}{2}, \quad [\text{amps}]$$

$$I_{pk} = 1.6, \quad [\text{amps}]$$

Step No. 3 Calculate the energy-handling capability.

$$\text{Energy} = \frac{LI_{pk}^2}{2}, \quad [\text{watt-seconds}]$$

$$\text{Energy} = \frac{(0.0025)(1.6)^2}{2}, \quad [\text{watt-seconds}]$$

$$\text{Energy} = 0.0032, \quad [\text{watt-seconds}]$$

Step No. 4 Calculate the electrical conditions coefficient,  $K_e$ .

$$K_e = 0.145 P_o B_m^2 (10^{-4})$$

$$K_e = 0.145(100)(0.22)^2 (10^{-4})$$

$$K_e = 0.0000702$$

Step No. 5 Calculate the core geometry coefficient,  $K_g$ .

$$K_g = \frac{(\text{Energy})^2}{K_e \alpha}, \quad [\text{cm}^5]$$

$$K_g = \frac{(0.0032)^2}{(0.0000702)(1.0)}, \quad [\text{cm}^5]$$

$$K_g = 0.146, \quad [\text{cm}^5]$$

Step No. 6 Select an ETD ferrite core from Chapter 3. The data listed is the closest core to the calculated core geometry,  $K_g$ .

- |                                    |                         |
|------------------------------------|-------------------------|
| 1. Core Number .....               | = ETD-39                |
| 2. Magnetic Path Length, MPL ..... | = 9.22 cm               |
| 3. Core Weight, $W_{ife}$ .....    | = 60 grams              |
| 4. Mean Length Turn, MLT .....     | = 8.3 cm                |
| 5. Iron Area, $A_c$ .....          | = 1.252 cm <sup>2</sup> |
| 6. Window Area, $W_a$ .....        | = 2.34 cm <sup>2</sup>  |
| 7. Area Product, $A_p$ .....       | = 2.93 cm <sup>4</sup>  |
| 8. Core Geometry, $K_g$ .....      | = 0.177 cm <sup>5</sup> |
| 9. Surface Area, $A_t$ .....       | = 69.9 cm <sup>2</sup>  |
| 10. Material, P .....              | = 2500 $\mu$            |
| 11. Millihenrys-per-1k, AL .....   | = 3295 mh               |
| 12. Winding Length, G .....        | = 2.84 cm               |

Step No. 7 Calculate the current density,  $J$ , using the area product equation,  $A_p$ .

$$J = \frac{2(\text{Energy})(10^4)}{B_m A_p K_u}, \quad [\text{amps-per-cm}^2]$$

$$J = \frac{2(0.0032)(10^4)}{(0.22)(2.93)(0.4)}, \quad [\text{amps-per-cm}^2]$$

$$J = 248, \quad [\text{amps-per-cm}^2]$$

Step No. 8 Calculate the rms current,  $I_{rms}$ .

$$I_{rms} = \sqrt{I_o^2 + \Delta I^2}, \quad [\text{amps}]$$

$$I_{rms} = \sqrt{(1.5)^2 + (0.2)^2}, \quad [\text{amps}]$$

$$I_{rms} = 1.51, \quad [\text{amps}]$$

Step No. 9 Calculate the required bare wire area,  $A_{w(B)}$ .

$$A_{W(B)} = \frac{I_{rms}}{J}, \quad [\text{cm}^2]$$

$$A_{W(B)} = \frac{(1.51)}{(248)}, \quad [\text{cm}^2]$$

$$A_{W(B)} = 0.00609, \quad [\text{cm}^2]$$

Step No. 10 Select a wire from the Wire Table in Chapter 4. If the area is not within 10%, take the next smallest size. Also, record the micro-ohms per centimeter.

$$\text{AWG} = \#19$$

$$\text{Bare, } A_{W(B)} = 0.00653, \quad [\text{cm}^2]$$

$$\text{Insulated, } A_w = 0.00754, \quad [\text{cm}^2]$$

$$\left( \frac{\mu\Omega}{\text{cm}} \right) = 264, \quad [\text{micro-ohm/cm}]$$

Step No. 11 Calculate the effective window area,  $W_{a(\text{eff})}$ . Using the window area found in Step 6. A typical value for,  $S_3$ , is 0.75, as shown in Chapter 4.

$$W_{a(\text{eff})} = W_a S_3, \quad [\text{cm}^2]$$

$$W_{a(\text{eff})} = (2.34)(0.75), \quad [\text{cm}^2]$$

$$W_{a(\text{eff})} = 1.76, \quad [\text{cm}^2]$$



Step No. 12 Calculate the number turns possible, N, using the insulated wire area,  $A_w$ , found in Step 10. A typical value for,  $S_2$ , is 0.6, as shown in Chapter 4.

$$N = \frac{W_{a(eff)} S_2}{A_w}, \quad [\text{turns}]$$

$$N = \frac{(1.76)(0.60)}{(0.00754)}, \quad [\text{turns}]$$

$$N = 140, \quad [\text{turns}]$$

Step No. 13 Calculate the required gap,  $l_g$ .

$$l_g = \frac{0.4\pi N^2 A_c (10^{-8})}{L} - \left( \frac{\text{MPL}}{\mu_m} \right), \quad [\text{cm}]$$

$$l_g = \frac{(1.26)(140)^2 (1.25)(10^{-8})}{(0.0025)} - \left( \frac{9.22}{2500} \right), \quad [\text{cm}]$$

$$l_g = 0.120, \quad [\text{cm}]$$

Step No. 14 Calculate the equivalent gap in mils.

$$\text{mils} = \text{cm}(393.7)$$

$$\text{mils} = (0.120)(393.7)$$

$$\text{mils} = 47.2 \text{ use } 50$$

Step No. 15 Calculate the fringing flux factor, F.

$$F = 1 + \frac{l_g}{\sqrt{A_c}} \ln \left( \frac{2G}{l_g} \right)$$

$$F = 1 + \frac{(0.120)}{\sqrt{1.25}} \ln \left( \frac{2(2.84)}{0.120} \right)$$

$$F = 1.41$$

Step No. 16 Calculate the new number of turns,  $N_n$ , by inserting the fringing flux, F.

$$N_n = \sqrt{\frac{l_g L}{0.4\pi A_c F (10^{-8})}}, \quad [\text{turns}]$$

$$N_n = \sqrt{\frac{(0.120)(0.0025)}{(1.26)(1.25)(1.41)(10^{-8})}}, \quad [\text{turns}]$$

$$N_n = 116, \quad [\text{turns}]$$

Step No. 17 Calculate the winding resistance,  $R_L$ . Use the MLT from Step 6 and the micro-ohm per centimeter from Step 10.

$$R_L = (\text{MLT})(N_n) \left( \frac{\mu\Omega}{\text{cm}} \right) (10^{-6}), \text{ [ohms]}$$

$$R_L = (8.3)(116)(264)(10^{-6}), \text{ [ohms]}$$

$$R_L = 0.254, \text{ [ohms]}$$

Step No. 18 Calculate the copper loss,  $P_{cu}$ .

$$P_{cu} = I_{rms}^2 R_L, \text{ [watts]}$$

$$P_{cu} = (1.51)^2 (0.254), \text{ [watts]}$$

$$P_{cu} = 0.579, \text{ [watts]}$$

Step No. 19 Calculate the regulation,  $\alpha$ .

$$\alpha = \frac{P_{cu}}{P_o} (100), \text{ [%]}$$

$$\alpha = \frac{(0.579)}{(100)} (100), \text{ [%]}$$

$$\alpha = 0.579, \text{ [%]}$$

Step No. 20 Calculate the ac flux density,  $B_{ac}$ .

$$B_{ac} = \frac{0.4\pi N_n F \left( \frac{\Delta I}{2} \right) (10^{-4})}{l_g + \left( \frac{\text{MPL}}{\mu_m} \right)}, \text{ [tesla]}$$

$$B_{ac} = \frac{(1.26)(116)(1.41) \left( \frac{0.2}{2} \right) (10^{-4})}{(0.120) + \left( \frac{9.22}{2500} \right)}, \text{ [tesla]}$$

$$B_{ac} = 0.0167, \text{ [tesla]}$$

Step No. 21 Calculate the watts per kilogram for ferrite, P, material in Chapter 2. Watts per kilogram can be written in milliwatts per gram.

$$\text{mW/g} = k f^{(m)} B_{ac}^{(n)}$$

$$\text{mW/g} = (0.00004855)(200000)^{(1.63)} (0.0167)^{(2.62)}$$

$$\text{mW/g} = 0.468$$

Step No. 22 Calculate the core loss,  $P_{fe}$ .

$$P_{fe} = (\text{mW/g})(W_{fe})(10^{-3}), \text{ [watts]}$$

$$P_{fe} = (0.468)(60)(10^{-3}), \text{ [watts]}$$

$$P_{fe} = 0.0281, \text{ [watts]}$$

Step No. 23 Calculate the total loss, copper plus iron,  $P_{\Sigma}$ .

$$P_{\Sigma} = P_{fe} + P_{cu}, \text{ [watts]}$$

$$P_{\Sigma} = (0.0281) + (0.579), \text{ [watts]}$$

$$P_{\Sigma} = 0.607, \text{ [watts]}$$

Step No. 24 Calculate the watt density,  $\psi$ . The surface area,  $A_t$ , can be found in Step 6.

$$\psi = \frac{P_{\Sigma}}{A_t}, \text{ [watts/cm}^2\text{]}$$

$$\psi = \frac{(0.607)}{(69.9)}, \text{ [watts/cm}^2\text{]}$$

$$\psi = 0.00868, \text{ [watts/cm}^2\text{]}$$

Step No. 25 Calculate the temperature rise,  $T_r$ .

$$T_r = 450(\psi)^{(0.826)}, \text{ [}^{\circ}\text{C]}$$

$$T_r = 450(0.00868)^{(0.826)}, \text{ [}^{\circ}\text{C]}$$

$$T_r = 8.92, \text{ [}^{\circ}\text{C]}$$

Step No. 26 Calculate the peak flux density,  $B_{pk}$ .

$$B_{pk} = \frac{0.4\pi N_n F \left( I_{dc} + \frac{\Delta I}{2} \right) (10^{-4})}{l_g + \left( \frac{\text{MPL}}{\mu_m} \right)}, \text{ [tesla]}$$

$$B_{pk} = \frac{(1.26)(116)(1.41)(1.6)(10^{-4})}{(0.127) + \left( \frac{9.22}{2500} \right)}, \text{ [tesla]}$$

$$B_{pk} = 0.252, \text{ [tesla]}$$

**Note:**

The big advantage in using the core geometry design procedure is that the wire current density is calculated. When using the area product design procedure, the current density is an estimate, at best. In this next design the same current density will be used as in the core geometry design.

**Gapped Inductor Design Example Using the Area Product,  $A_p$ , Approach**

Step No. 1 Design a linear dc inductor with the following specifications:

- 1. Inductance, L ..... = 0.0025 henrys
- 2. dc current,  $I_o$  ..... = 1.5 amps
- 3. ac current,  $\Delta I$  ..... = 0.2 amps
- 4. Output power,  $P_o$  ..... = 100 watts
- 5. Current Density, J ..... = 250 amps-per-cm<sup>2</sup>
- 6. Ripple Frequency ..... = 200 kHz
- 7. Operating flux density,  $B_m$  ..... = 0.22 tesla
- 8. Core Material ..... = ferrite
- 9. Window utilization,  $K_u$  ..... = 0.4
- 10. Temperature rise goal,  $T_r$  ..... = 25°C

Step No. 2 Calculate the peak current,  $I_{pk}$ .

$$I_{pk} = I_o + \frac{\Delta I}{2}, \text{ [amps]}$$

$$I_{pk} = (1.5) + \frac{(0.2)}{2}, \text{ [amps]}$$

$$I_{pk} = 1.6, \text{ [amps]}$$

Step No. 3 Calculate the energy-handling capability.

$$\text{Energy} = \frac{L I_{pk}^2}{2}, \text{ [watt-seconds]}$$

$$\text{Energy} = \frac{(0.0025)(1.6)^2}{2}, \text{ [watt-seconds]}$$

$$\text{Energy} = 0.0032, \text{ [watt-seconds]}$$

Step No. 4 Calculate the area product,  $A_p$ .

$$A_p = \frac{2(\text{Energy})(10^4)}{B_m J K_u}, \quad [\text{cm}^4]$$

$$A_p = \frac{2(0.0032)(10^4)}{(0.22)(248)(0.4)}, \quad [\text{cm}^4]$$

$$A_p = 2.93, \quad [\text{cm}^4]$$

Step No. 5 Select an ETD ferrite core from Chapter 3. The data listed is the closest core to the calculated area product,  $A_p$ .

- |                                    |                         |
|------------------------------------|-------------------------|
| 1. Core Number .....               | = ETD-39                |
| 2. Magnetic Path Length, MPL ..... | = 9.22 cm               |
| 3. Core Weight, $W_{tfe}$ .....    | = 60 grams              |
| 4. Mean Length Turn, MLT .....     | = 8.3 cm                |
| 5. Iron Area, $A_c$ .....          | = 1.252 cm <sup>2</sup> |
| 6. Window Area, $W_a$ .....        | = 2.34 cm <sup>2</sup>  |
| 7. Area Product, $A_p$ .....       | = 2.93 cm <sup>4</sup>  |
| 8. Core Geometry, $K_g$ .....      | = 0.177 cm <sup>5</sup> |
| 9. Surface Area, $A_t$ .....       | = 69.9 cm <sup>2</sup>  |
| 10. Material, P .....              | = 2500μ                 |
| 11. Millihenrys-per-1k, A L .....  | = 3295 mh               |
| 12. Winding Length, G .....        | = 2.84 cm               |

Step No. 6 Calculate the rms current,  $I_{rms}$ .

$$I_{rms} = \sqrt{I_o^2 + \Delta I^2}, \quad [\text{amps}]$$

$$I_{rms} = \sqrt{(1.5)^2 + (0.2)^2}, \quad [\text{amps}]$$

$$I_{rms} = 1.51, \quad [\text{amps}]$$

Step No. 7 Calculate the required bare wire area,  $A_{w(B)}$ .

$$A_{w(B)} = \frac{I_{rms}}{J}, \quad [\text{cm}^2]$$

$$A_{w(B)} = \frac{(1.51)}{(248)}, \quad [\text{cm}^2]$$

$$A_{w(B)} = 0.00609, \quad [\text{cm}^2]$$

Step No. 8 Select a wire from the Wire Table in Chapter 4. If the area is not within 10%, take the next smallest size. Also, record micro-ohms per centimeter.

$$\text{AWG} = \#19$$

$$\text{Bare, } A_{w(b)} = 0.00653, \text{ [cm}^2\text{]}$$

$$\text{Insulated, } A_w = 0.00754, \text{ [cm}^2\text{]}$$

$$\left(\frac{\mu\Omega}{\text{cm}}\right) = 264, \text{ [micro-ohm/cm]}$$

Step No. 9 Calculate the effective window area,  $W_{a(\text{eff})}$ . Use the window area found in Step 6. A typical value for,  $S_3$ , is 0.75, as shown in Chapter 4.

$$W_{a(\text{eff})} = W_a S_3, \text{ [cm}^2\text{]}$$

$$W_{a(\text{eff})} = (2.34)(0.75), \text{ [cm}^2\text{]}$$

$$W_{a(\text{eff})} = 1.76, \text{ [cm}^2\text{]}$$

Step No. 10 Calculate the number turns possible,  $N$ , using the insulated wire area,  $A_w$  found in Step 8. A typical value for,  $S_2$ , is 0.6, as shown in Chapter 4.

$$N = \frac{W_{a(\text{eff})} S_2}{A_w}, \text{ [turns]}$$

$$N = \frac{(1.76)(0.60)}{(0.00754)}, \text{ [turns]}$$

$$N = 140, \text{ [turns]}$$

Step No. 11 Calculate the required gap,  $l_g$ .

$$l_g = \frac{0.4\pi N^2 A_c (10^{-8})}{L} - \left(\frac{\text{MPL}}{\mu_m}\right), \text{ [cm]}$$

$$l_g = \frac{(1.26)(140)^2 (1.25)(10^{-8})}{(0.0025)} - \left(\frac{9.22}{2500}\right), \text{ [cm]}$$

$$l_g = 0.120, \text{ [cm]}$$

Step No. 12 Calculate the equivalent gap in mils.

$$\text{mils} = \text{cm}(393.7)$$

$$\text{mils} = (0.120)(393.7)$$

$$\text{mils} = 47.2 \text{ use } 50$$

Step No. 13 Calculate the fringing flux factor, F.

$$F = 1 + \frac{l_g}{\sqrt{A_c}} \ln \left( \frac{2G}{l_g} \right)$$

$$F = 1 + \frac{(0.120)}{\sqrt{1.25}} \ln \left( \frac{2(2.84)}{0.120} \right)$$

$$F = 1.41$$

Step No. 14 Calculate the new number of turns,  $N_n$ , by inserting the fringing flux, F.

$$N_n = \sqrt{\frac{l_g L}{0.4\pi A_c F (10^{-8})}}, \text{ [turns]}$$

$$N_n = \sqrt{\frac{(0.120)(0.0025)}{(1.26)(1.25)(1.41)(10^{-8})}}, \text{ [turns]}$$

$$N_n = 116, \text{ [turns]}$$

Step No. 15 Calculate the winding resistance,  $R_L$ . Use the MLT, from Step 5, and the micro-ohm per centimeter, from Step 10.

$$R_L = (\text{MLT})(N_n) \left( \frac{\mu\Omega}{\text{cm}} \right) (10^{-6}), \text{ [ohms]}$$

$$R_L = (8.3)(116)(264)(10^{-6}), \text{ [ohms]}$$

$$R_L = 0.254, \text{ [ohms]}$$

Step No. 16 Calculate the copper loss,  $P_{cu}$ .

$$P_{cu} = I_{rms}^2 R_L, \text{ [watts]}$$

$$P_{cu} = (1.51)^2 (0.254), \text{ [watts]}$$

$$P_{cu} = 0.579, \text{ [watts]}$$

Step No. 17 Calculate the regulation,  $\alpha$ .

$$\alpha = \frac{P_{cu}}{P_o} (100), \text{ [%]}$$

$$\alpha = \frac{(0.579)}{(100)} (100), \text{ [%]}$$

$$\alpha = 0.579, \text{ [%]}$$

Step No. 18 Calculate the ac flux density,  $B_{ac}$ .

$$B_{ac} = \frac{0.4\pi N_n F \left( \frac{\Delta l}{2} \right) (10^{-4})}{l_g + \left( \frac{MPL}{\mu_m} \right)}, \quad [\text{tesla}]$$

$$B_{ac} = \frac{(1.26)(116)(1.41) \left( \frac{0.2}{2} \right) (10^{-4})}{(0.120) + \left( \frac{9.22}{2500} \right)}, \quad [\text{tesla}]$$

$$B_{ac} = 0.0167, \quad [\text{tesla}]$$

Step No. 19 Calculate the watts per kilogram for ferrite,  $P$ , material in Chapter 2. Watts per kilogram can be written in milliwatts per gram.

$$\text{mW/g} = k f^{(m)} B_{ac}^{(n)}$$

$$\text{mW/g} = (0.00004855)(200000)^{(1.63)} (0.0167)^{(2.62)}$$

$$\text{mW/g} = 0.468$$

Step No. 20 Calculate the core loss,  $P_{fe}$ .

$$P_{fe} = (\text{mW/g})(W_{fe})(10^{-3}), \quad [\text{watts}]$$

$$P_{fe} = (0.468)(60)(10^{-3}), \quad [\text{watts}]$$

$$P_{fe} = 0.0281, \quad [\text{watts}]$$

Step No. 21 Calculate the total loss copper plus iron,  $P_{\Sigma}$ .

$$P_{\Sigma} = P_{fe} + P_{cu}, \quad [\text{watts}]$$

$$P_{\Sigma} = (0.0281) + (0.579), \quad [\text{watts}]$$

$$P_{\Sigma} = 0.607, \quad [\text{watts}]$$

Step No. 22 Calculate the watt density,  $\psi$ . The surface area,  $A_i$ , can be found in Step 5.

$$\psi = \frac{P_{\Sigma}}{A_i}, \quad [\text{watts/cm}^2]$$

$$\psi = \frac{(0.607)}{(69.9)}, \quad [\text{watts/cm}^2]$$

$$\psi = 0.00868, \quad [\text{watts/cm}^2]$$



Step No. 23 Calculate the temperature rise,  $T_r$ .

$$T_r = 450(\psi)^{(0.826)}, \quad [^{\circ}\text{C}]$$

$$T_r = 450(0.00868)^{(0.826)}, \quad [^{\circ}\text{C}]$$

$$T_r = 8.92, \quad [^{\circ}\text{C}]$$

Step No. 24 Calculate the peak flux density,  $B_{pk}$ .

$$B_{pk} = \frac{0.4\pi N_n F \left( I_{dc} + \frac{\Delta I}{2} \right) (10^{-4})}{l_g + \left( \frac{\text{MPL}}{\mu_m} \right)}, \quad [\text{tesla}]$$

$$B_{pk} = \frac{(1.26)(116)(1.41)(1.6)(10^{-4})}{(0.127) + \left( \frac{9.22}{2500} \right)}, \quad [\text{tesla}]$$

$$B_{pk} = 0.252, \quad [\text{tesla}]$$

Step No. 25 Calculate the effective permeability,  $\mu_e$ . Knowing the effective permeability, the ETD-39 ferrite core can be ordered with a built in gap.

$$\mu_e = \frac{\mu_m}{1 + \left( \frac{l_g}{\text{MPL}} \right) \mu_m}$$

$$\mu_e = \frac{(2500)}{1 + \left( \frac{(0.120)}{9.22} \right) (2500)}$$

$$\mu_e = 74.5 \quad \text{use } 75$$

Step No. 26 Calculate the window utilization,  $K_u$ .

$$K_u = \frac{N_n A_w(B)}{W_a}$$

$$K_u = \frac{(116)(0.00653)}{(2.34)}$$

$$K_u = 0.324$$